



TRANSPORT PACKAGING SOLUTIONS

# PallRun®

Environmentally friendly pallet alternative



Sustainable packaging is your contribution to the environment



# Sustainable packaging is your a

## WHAT IS A PALLRUN®?

PallRun® is a transport packaging element from Eltete TPM Ltd. It is a 100% recyclable carton board pallet foot for replacing wooden or other kinds of palletterunners/pallets. It is a combination of compact cartonboard (U-profiles) and stabilisation elements (cores). The surface of the U-profile is reinforced by wet strengthened kraftliner giving high protection for humidity. The PallRun® can also be provided with self-adhesive surface for easier fastening.

## ENVIRONMENTALLY FRIENDLY WOODFREE PACKAGING

New restrictions for packaging: In order to prevent harmful spread of pests, the International Standard ISPM 15 requires that wooden pallets must be treated and marked before they can be imported to several countries such as the European Union, USA, Canada, China, Australia etc. New environmental and hygienic measures mean change. Many sectors have already chosen the carton board for their packaging in order to avoid any extra handling costs or problems in importing their goods to different countries.

### PALLET ASSEMBLY IN LESS THAN 30 SECONDS

Space need in warehousing can be reduced 80%



**150 SELF-ADHESIVE PALLRUNS®  
+ 50 SURFACE TOP BOARDS**



**= 50 CARTON PALLETS**

### SAVINGS

- need for space in the warehousing will be minimized
- PallRuns® are light in weight (difference to a wooden pallet approx. 12 kg) – huge savings in air freight!
- material and handling cost can be reduced
- savings in recycling costs

### EASY HANDLING

- it is possible to make any size of a pallet or directly attach the PallRuns® under a box or a display
- the material contains no nails and produces no splinters – it's very user friendly
- PallRuns® are strong, resistant for humidity and they can be tailored according to the strength needed

### HYGIENIC AND RECYCLABLE

- PallRuns® are 100% recyclable carton board
- recycling together with any carton
- each pallet is new, clean and good looking
- "green thinking" gives a good company image
- PallRuns® need no treatments or markings like wood

# Contribution to the Environment

## POSSIBILITIES

There are many ways to use the PallRuns® wherever there is need of palletizing in a modern way. They suit with all existing methods of palletizing and transport packaging.

The PallRuns® can be combined with different surface top boards such as corrugated board, honeycomb, chipboard or just PallRuns® attached directly to the product. Both 2- and 4-way pallets are available. Let us help you to find the right solution for your needs!

## PALLRUN® CAN BE COMBINED IN VARIOUS WAYS:

PallRun®



PallRun® with hotmelt



EDGEBOARDS  
attached with a staple gun

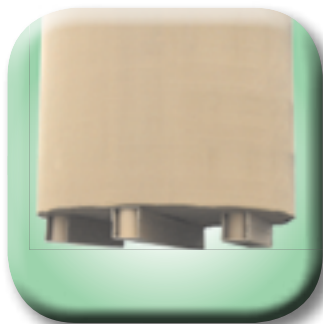

PAPERROLL  
- ventilation  
- roll raiser  
- forklift use



SURFACE TOP BOARD  
2- or 4-way



BOX OR DISPLAY  
directly under the box

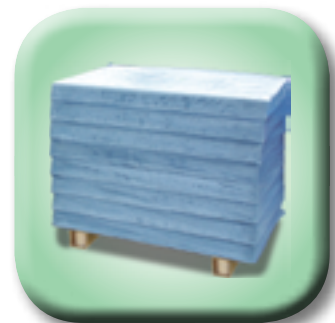

WOOD OR OTHER PRODUCT  
directly attached to the product

## WHAT ABOUT THE SIZES OF THE PALLRUNS®?

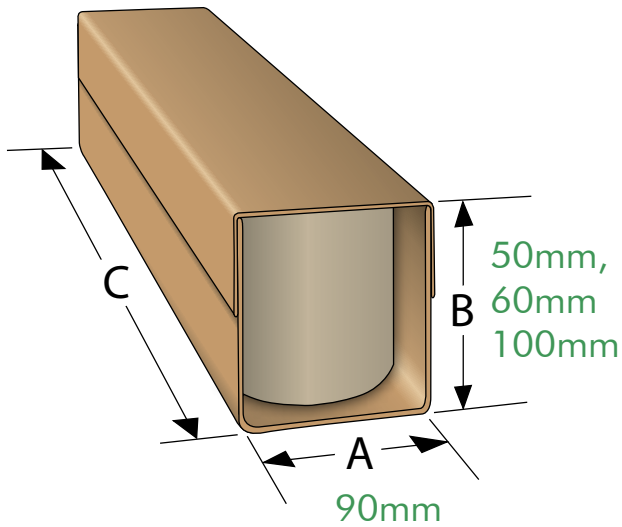

Standard lengths (**C**): 190, 400, 600, 800, 1000 and 1200mm.

## WHAT ABOUT STRENGTH?

Independent laboratory tests made by SCA Packaging Ltd in the United Kingdom, have demonstrated that in a static compression test a normal size pallet with Eltete PallRuns® could take a load of 10 000 kg with no failure. In order to find the correct strength, the pallets are always designed and tested according to the needs and special requirements of each application.

## WHAT ABOUT MOISTURE?

The surface material of the PallRun® is reinforced with wet strengthened kraftliner giving high protection for humidity. Eltete PallRuns® are much more resistant to humidity than other similar kind of palleterunners.

## WHAT ABOUT USING PALLRUNS® ON A ROLL CONVEYOR?

Tests have proven that Eltete PallRuns®, due to their especially strong structure, can perfectly be used on a roll conveyor. The structure is strong enough to support different kinds of movements.

Eltete TPM Ltd (Transport Packaging Materials) is a global carton board refiner, an ISO-certified supplier of 100% recyclable transport packaging material and a machine producer. With experience since 1974, we are experts on the needs of today's market. Innovative and high-quality packaging solutions made of compact carton board are being offered in more than 60 countries through the Eltete sales organisation. With production sites in 14 countries, Eltete TPM is one of the leading producers of edgeboards and packaging solutions in the world.

## SHOP DISPLAYS

The ideal solution for a supermarket is to have a total carton board packaging system, which enables them to recycle the whole display at once. PallRuns® are also hygienic and therefore well accepted. Times are changing and some countries already require that all shop displays and pallets should be made out of carton board.

## LOADEDGE

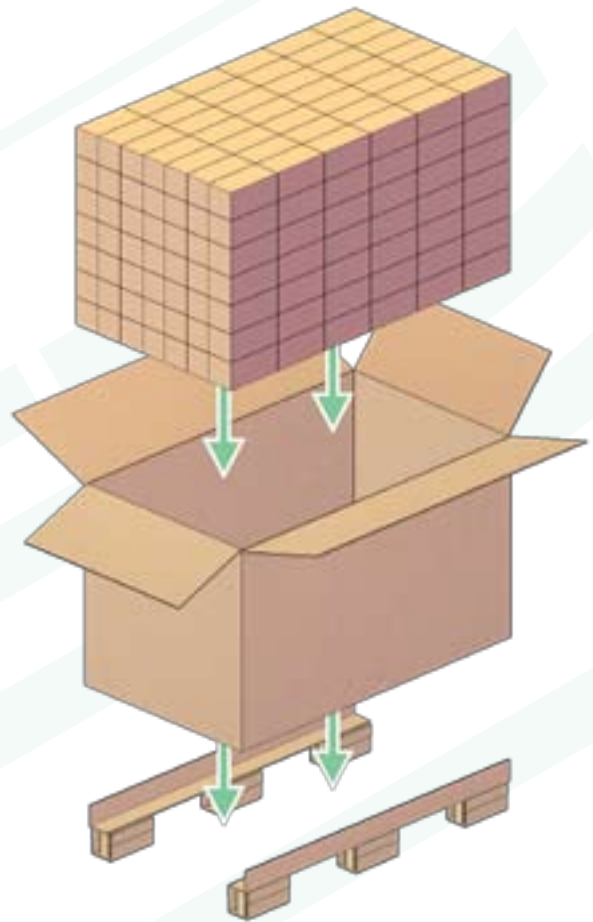

Eltete LoadEdge is a combination of PallRuns®'s and bio-quality edgeboards.

Use it with:

- Corrugated boxes
- Shop displays
- Other tailor-made applications

### Headquarters

Eltete TPM Ltd  
P.O.Box 94  
FIN-07901 Loviisa, FINLAND  
Tel. +358 (0)19 510 31  
Fax. +358 (0)19 510 3200  
E-mail: info@eltete.com  
Internet: www.eltete.com